

CLAMPB®

STRONG-ARM



FOLDING CRANE

MODEL NO: CFC100

PART NO: 7611005

OPERATING & MAINTENANCE INSTRUCTIONS

UK
CA | CE

ORIGINAL INSTRUCTIONS

GC12/22 Rev 5

INTRODUCTION

Thank you for purchasing this CLARKE Hydraulic Crane.

Before attempting to use this product, please read this manual thoroughly and follow the instructions carefully. In doing so you will ensure the safety of yourself and that of others around you, and you can look forward to your purchase giving you long and satisfactory service.

GUARANTEE

This product is guaranteed against faulty manufacture for a period of 12 months from the date of purchase. Please keep your receipt which will be required as proof of purchase.

This guarantee is invalid if the product is found to have been abused or tampered with in any way, or not used for the purpose for which it was intended.

Faulty goods should be returned to their place of purchase, no product can be returned to us without prior permission. This guarantee does not effect your statutory rights.

SPECIFICATION

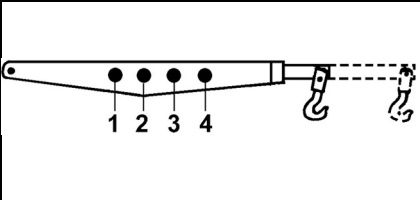
	Position 1	Position 2	Position 3	Position 4
Lifting Capacity (kg)	1000	750	500	250
Max Lift Height (mm)	1815	1880	1945	2010
Min. Lift Height (mm)	900	990	1080	1170
Overall Width (mm)	1030			
Width Between Legs (mm)	890			
Height of Legs	150			
Weight (kgs)	74			

Please note that the details and specifications contained herein are correct at the time of going to print. However Clarke International reserve the right to change specifications at any time without prior notice.

GENERAL SAFETY RULES



WARNING: FAILURE TO FOLLOW THESE PRECAUTIONS COULD RESULT IN PERSONAL INJURY, AND/OR DAMAGE TO PROPERTY.

1. Always read instructions before setting up the equipment and before use.
2. Always inspect the crane before use to ensure it is correctly assembled and in good condition, and replace any damaged or worn parts.
3. When replacing parts, use only those supplied by Clarke International.
4. Never exceed the safe working load capacities specified on the jib for each position (as marked on the jib).

IMPORTANT: If the load capacity label becomes worn or illegible, contact Clarke Parts and service department, on 0208 988 7400 for a replacement.

5. Only use chains, slings, hooks etc. with a rated capacity equal to, or greater than that of the load. Check that they are secure and will not slip under load.
6. Only use the crane on a flat, solid, level surface that is capable of bearing the weight of the load.
7. Lower the load as much as possible before moving the crane. Do not use the crane to transport loads.
8. Use appropriate safety equipment, such as protective footwear, when using this crane.
9. Ensure the crane operator is trained in both operation and safety aspects.
10. Do not allow the load to swing or drop suddenly.
11. If the crane has been subjected to an abnormal load or shock, it should be removed from service immediately and fully inspected by qualified personnel.
12. Ensure that the crane is properly maintained and lubricated at all times, and that corrosion is not allowed to weaken any component.
13. Do not use around children or untrained persons.
14. This is a heavy item. Take care when moving.
15. Do not use this crane to lift people.
16. Do not work under any suspended load.

PARTS SUPPLIED

Unpack the crane on to a clean flat area of hard standing, and visually inspect components to ensure that no damage was suffered in transit. Should any damage be apparent, please contact your Clarke dealer immediately.

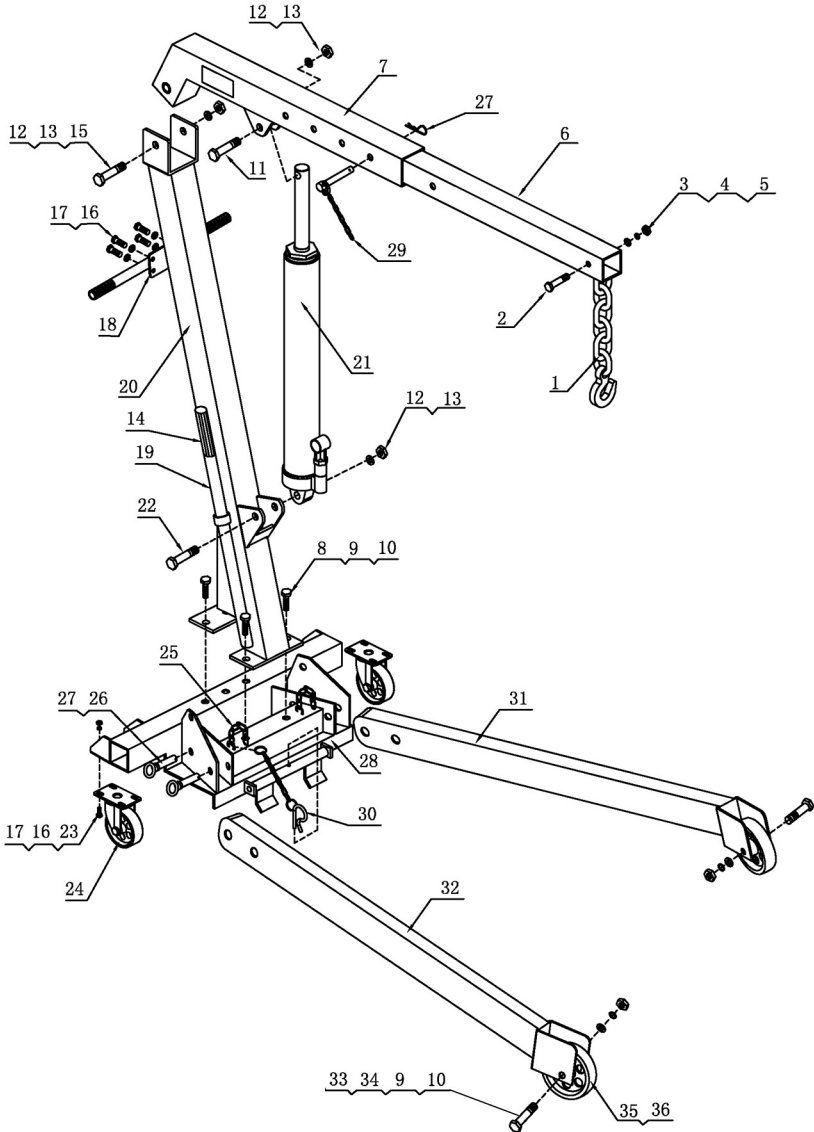

COMPONENT PARTS LIST

No	Description
1	Chain and hook assembly
2	Bolt M12x80
3	Flat washer M12
4	Lockwasher M12
5	Nut M12
6	Jib extension
7	Jib
8	Bolt M14 x 100
9	Flat washer M14
10	Nut M14
11	Bolt M16 x 70
12	Flat washer M16
13	Nut M16
14	Handle grip
15	Bolt M16x110
16	Bolt M8x20
17	Lock was he M8
18	Handle

No	Description
19	Pump handle
20	Main support post
21	Ram
22	Bolt M16 x 90
23	Nut M8
24	Castor wheel
25	Chain
26	Lock Pin
27	R-clip
28	Base
29	Pin assembly
30	R-clip and chain
31	Left leg
32	Right leg
33	Bolt M14x85
34	Lockwasher M8
35	5" wheel
36	Bushing

ASSEMBLY

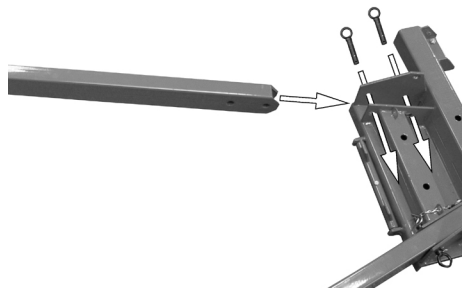
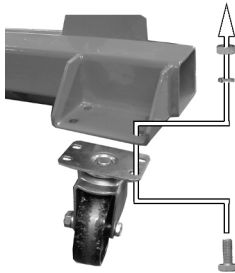

1. Fit the castor (24) to the base (28) using 4 bolts (16), lock washers (17) and nuts (23).
2. Repeat for both castors.

3. Slide the right leg (32) into the base (28) as shown, line up the holes and insert two lock pins (26).
4. Repeat the procedure for the left leg (31).



5. Secure the pins using the R clips (27) and small chains (25).
 - Make sure the chain passes through the loop shown on the left.



6. Attach the main support post (20) onto the base assembly (28) using five bolts (8), five washers (9) and five nuts (10).

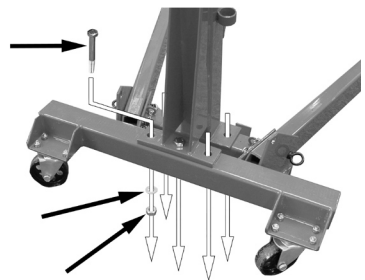

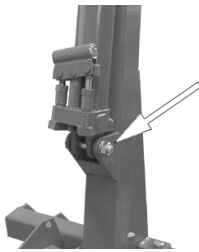

7. Fix the ram (21) into position using bolt (22), washer (12) and nut (13)

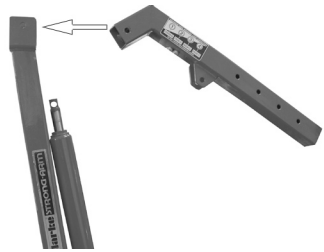

8. Attach the jib (7) to the top of the main support post (20) using bolt (15), washer (12) and nut (13).

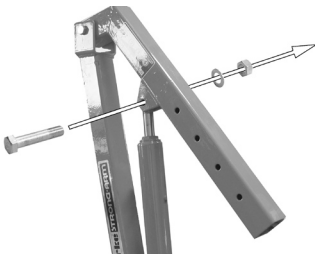

9. Connect the top of the ram (21) to the jib (7) as shown using bolt (11), washer (12) and nut (13).

NOTE: The ram may require extending to facilitate assembly, see page 8.



10. Slide the jib extension (6) into the jib (7), use the pin assembly (29) to lock it into the required position

The pin is secured by inserting the attached R clip into the small hole at the other end of the pin.

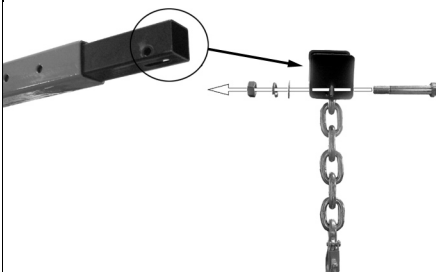

11. Pass the last link of the chain and hook assembly (1) through the hole on the bottom of the jib extension (6). Secure the chain using bolt (2), washer (3), lock washer (4) and nut (5).

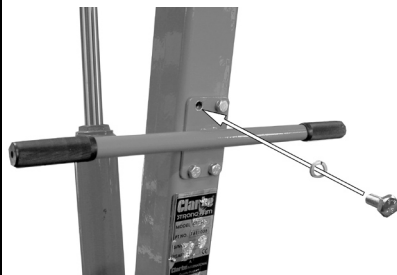

12. Connect the handle (18) to the rear of the main support post (20) using four bolts (16), and four lock washers (17).

OPERATION

RAISING THE JIB

Important;- Make sure that the hook is directly above the point of lift, which in turn is directly above the centre of gravity of the load.

1. Use the end of the pump handle (19) to close the valve by turning it fully clockwise.
 - It should be hand tight, do not overtighten.
2. Return the pump handle (19) to the pump linkage and pump the handle until the crane reaches the desired height.

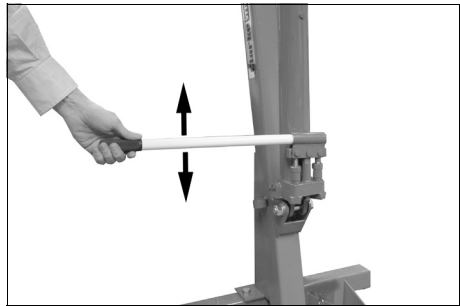
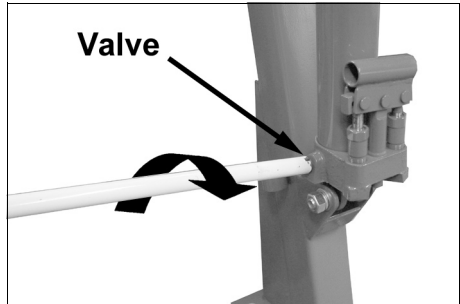

LOWERING THE JIB

1. Use the end of the pump handle (19) to turn the valve anticlockwise VERY SLOWLY.
 - The speed of lowering the load is controlled by how much you turn the valve.

EXTENDING THE JIB

1. Raise the jib until horizontal.
2. Remove the locating pin assembly (29) & withdraw the pin.
3. Reposition the jib extension to the desired length.
4. Replace the pin assembly (29) ensuring the 'R' clip is firmly in place



NOTES:

During transit or storage, it is possible that an air pocket may have developed within the hydraulic ram, and the ram action may therefore appear to be 'spongy'. As the ram is self bleeding, any air will be dispelled and the ram action normalized by fully raising and lowering the jib a few times. Should the jib not reach its full height, the oil level should be checked, as described in the Maintenance section.

STORAGE

ALWAYS get assistance when folding the crane into its storage configuration.

1. When storing, the stabiliser must be locked in the down position. You may need to tilt the crane back slightly to position the stabiliser correctly.

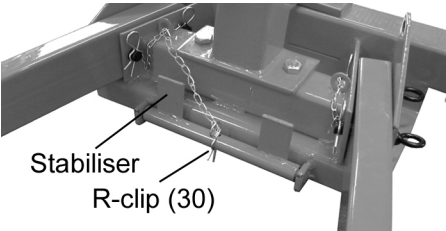
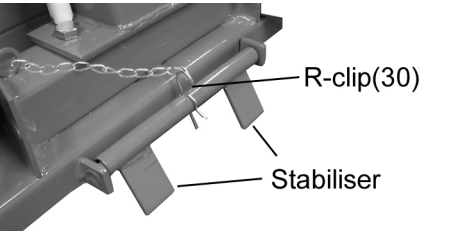
 <p>Stabiliser R-clip (30)</p>	 <p>R-clip(30) Stabiliser</p>
<p>During use</p> <p>The stabiliser should be placed in the up position and locked in place using the heavy duty R Clip (30)</p>	<p>During storage</p> <p>The stabiliser should be placed in the down position and locked in place using the heavy duty R Clip (30)</p>

2. With an assistant supporting the crane, pull out the 'R' clip (27), which secures the front leg lock pin, then pull out the lock pin.
3. Raise the leg up to the storage position.
4. Replace the leg lock pin (26), through the hole provided in the frame so that the leg is locked in the up position,
5. Replace the 'R' clip to secure the locking pin.
6. The pump handle (19) is housed in a bracket on the side of the main support post (20).
7. Once the crane is folded use extreme care when moving it to the storage location.



STORAGE WARNINGS

1. The crane **MUST** be firmly secured to a wall or fixed location when not in use.
2. Use a strong strap or chain or suitable restraint to prevent any accidental movement.
3. Test that the crane is firmly secured before leaving it in its storage location.

Alternatively you can lay the crane down and store it flat.

Always secure the jib in its lowest position.

MAINTENANCE

GENERAL

1. Always store the crane with the jib in its lowest position. This prevents any possibility of corrosion to the ram.
2. Do not leave the crane exposed to the elements. Keep under cover.
3. Do not attempt to adjust or tamper with the ram assembly, there are no serviceable parts. Contact your Clarke service department for servicing.
4. Always visually inspect the crane before use to ensure that all parts are correctly located and secure. Check for hydraulic leaks, signs of damage or worn parts and check the wheels and castors for serviceability.
5. A slight dampness on the ram is normal but where leakage is apparent the ram seals must be renewed. Consult your Clarke service department.

EVERY THREE MONTHS

1. Pins and bolts should be removed and inspected for wear, deformation or cracks. If any are apparent, the pin or bolt should be renewed.
2. Check the hydraulic ram operation and check the hydraulic oil level.

ANNUALLY

The crane should be fully inspected annually by a competent person.

1. Check wheels and castors to ensure they move freely without undue wear to their bores and that the wheels are not cracked or damaged.
2. Remove any rust or corrosion and repaint to prevent further corrosion.
3. Ensure that all decals and warning labels are in place and legible.

HYDRAULIC OIL

It may be necessary from time to time to top up the oil level as follows.

1. Lower the jib to its lowest position and remove the bolt that joins the ram (21) to the jib (7).
2. Rest the ram against the main support post and raise and prop up the jib (7). Use a cable or similar ensure the ram does not drop.
3. Remove the vent plug from the side of the ram.
4. Top up the oil until it is level with the hole before replacing the vent plug.
 - We recommend that the hydraulic oil is changed after every 100 hours of operation using Clarke hydraulic oil (part number 3050830).
 - Do not mix different types of oil.

DECLARATIONS OF CONFORMITY



Fitzwilliam Hall, Fitzwilliam Place, Dublin 2

DECLARATION OF CONFORMITY

This is an important document and should be retained.

We hereby declare that this product(s) complies with the following directive(s):
2006/42/EC Machinery Directive

The following standards have been applied to the product(s):
EN 1494:2000+A1:2008; EN/ISO 12100:2010

The technical documentation required to demonstrate that the product(s) meet(s) the requirement(s) of the applicable directive(s) has been compiled and is available for inspection by the relevant enforcement authorities.

The CE mark was first applied in: 2003

Product Description: 1 Tonne Folding Crane
Model number(s): CFC100
Serial / batch Number: N/A
Date of Issue: 19/12/2022

Signed:

J.A. Clarke
Director



Hemnal Steel, Epping, Essex CM16 4LG

DECLARATION OF CONFORMITY

This is an important document and should be retained.

We hereby declare that this product(s) complies with the following statutory requirement(s):
Supply of Machinery (Safety) Regulations 2008

The following standards have been applied to the product(s):
EN 1494:2000+A1:2008; EN/ISO 12100:2010

The technical documentation required to demonstrate that the product(s) meet(s) the requirement(s) of the applicable legislation has been compiled and is available for inspection by the relevant enforcement authorities.

The UKCA mark was first applied in: 2022

Product Description: 1 Tonne Folding Crane
Model number(s): CFC100
Serial / batch Number: N/A
Date of Issue: 19/12/2022

Signed:

J.A. Clarke
Director

A SELECTION FROM THE VAST RANGE OF

Clarke®

QUALITY PRODUCTS



AIR COMPRESSORS

From DIY to industrial, Plus air tools, spray guns and accessories.

GENERATORS

Prime duty or emergency standby for business, home and leisure.

POWER WASHERS

Hot and cold, electric and engine driven - we have what you need

WELDERS

Mig, Arc, Tig and Spot. From DIY to auto/industrial.

METALWORKING

Drills, grinders and saws for DIY and professional use.

WOODWORKING

Saws, sanders, lathes, mortisers and dust extraction.

HYDRAULICS

Cranes, body repair kits, transmission jacks for all types of workshop use.

WATER PUMPS

Submersible, electric and engine driven for DIY, agriculture and industry.

POWER TOOLS

Angle grinders, cordless drill sets, saws and sanders.

STARTERS/CHARGERS

All sizes for car and commercial use.

PARTS & SERVICE:

0208 988 7400

Parts Enquiries

Parts@clarkeinternational.com

Servicing & Technical Enquiries

Service@clarkeinternational.com

SALES: UK 01992 565333 or Export 00 44 (0)1992 565335

Clarke INTERNATIONAL Hemnall Street, Epping, Essex CM16 4LG
www.clarkeinternational.com